

MDM290 Piezoresistive OEM Differential Pressure sensor

Features

- Pressure range: 0~35kPa...3.5MPa
- Constant current power supply
- Isolated construction, enable to measure various media
- OEM differential pressure sensor
- Full 316L stainless steel
- High static pressure 20MPa



Application

- Industrial process control
- differential pressure measure
- gas, liquid pressure measure
- Pressure checking meter
- Pressure calibrator
- Ventura and eddy-current flow meter

Introduction

MDM290 piezoresistive differential pressure sensor is OEM differential pressure sensor with stainless steel isolated diaphragm. It has integrated construction, high static pressure, stable and reliable. The high and low pressure sides are protected by isolated diaphragm. It can be used for measuring corrosive and conductive flow media. The measured differential pressure is transmitted onto the die through the diaphragm and silicon oil, so that the sensor could measure differential pressure precisely. The sensor is tested on the advanced production line, with the popular dimension, MDM290 differential pressure sensor are widely used for industrial process control and differential pressure measure fields, etc.

Electric Performance

Power supply: $\leq 2.0\text{mA DC}$

Electric connection: 100mm silicon rubber flexible wires

Common mode voltage input: 50% of input (typ.)

Input impedance: $3\text{k}\Omega \sim 8\text{k}\Omega$

Output impedance: $3.5\text{k}\Omega \sim 6\text{k}\Omega$

Response (10%~90%): $< 1\text{ms}$

Insulation resistor: $100\text{M}\Omega$, 100VDC

Overpressure: to see datasheet

Max. static pressure: 20MPa

Zero drift/static pressure: $\leq 0.5\text{mV/MPa}$

Construction Specification

Diaphragm material: stainless steel 316L

Housing: stainless steel 316L

<http://www.microsensor.cn>

Add: No.18, Yingda Road Baoji, P.R.China, 721006

Tel: +86 917 3600739/3600832 Fax: 3600755

MICRO SENSOR CO.,LTD.

Pin: silicon rubber flexible wire

O-ring: Viton

Net weight: ~36g

Environment Condition

Position effect: deviate 90° from any orientation, zero change $\leq 0.2\%FS$

Shock: no change at 10gRMS, (20~2000) Hz

Impact: 100g, 11ms

Media compatibility: the gas or media which is compatible with stainless steel and Viton

Basic Condition

Media temperature: (25±1) °C

Environment temperature: (25±1) °C

Shock: 0.1g (1m/s/s) Max.

Humidity: (50%±10%) RH

Local air pressure: (86~106) kPa

Power supply: (1.5±0.0015) mADC

Basic Specification

Specification*	Min.	Typ.	Max.	Units
Specification		±0.15	±0.25	%FS,BFSL
Repeatability		±0.05	±0.075	%FS
Hysteresis		±0.05	±0.075	%FS
Zero output			±3	mVDC
FS output	60			mVDC
Zero thermal error		±1.0	±1.2	%FS, @25°C
Span thermal error		±1.0	±1.2	%FS, @25°C
Compensated temp. range	0~50			°C
Working temp. range	-40~125			°C
Storage temp. range	-40~125			°C
Long-term stability		±0.3	±0.5	%FS/year

*testing at basic condition

Outline Construction

(Units: mm)

<http://www.microsensor.cn>

Add: No.18,Yingda Road Baoji,P.R.China, 721006

Tel: +86 917 3600739/3600832 Fax: 3600755

MICRO SENSOR CO.,LTD.

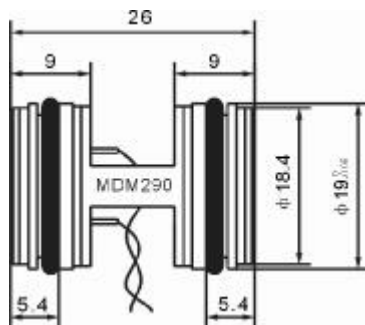

The suggested installation dimension is $\Phi 19^{+0.05}_{+0.02}$ mm

Electric Connection

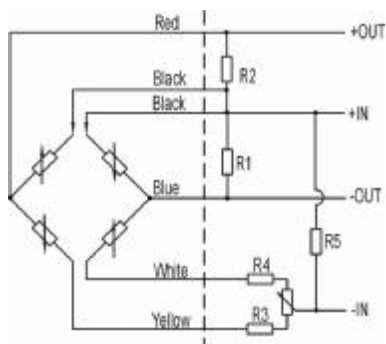

Wire color	Electric connection
Red	(+OUT)
Black	(+IN)
Black	(+IN)
Yellow	(-IN)
White	(-IN)
Blue	(-OUT)

1. The resistance bridge on the left of the dashed is sensor's bridge circuit;

2. MDM290 sensor has no laser trimming board, it compensates zero and temperature drift by outer compensated resistors, the connection to see the above chart; connect zero trimming resistor R3(R4), the other R4(R3) is short circuit as negative power supply; R1 or R2 is zero temperature drift compensated resistor, only one of them is used, the other is open circuit, please select the right resistor according to the specification label enclosed with sensor; R5 is sensitivity temperature compensated resistor. We suggest that please connect the outer resistor and differential pressure sensor as close as possible.

Order Guide

MDM290	Piezoresistive OEM Differential Pressure Sensor			
	Range code	Pressure range	Positive overpressure	Negative overpressure
	0A	0~35kPa	70kPa	35kPa
	02	0~70kPa	150kPa	70kPa
	03	0~100kPa	200kPa	100kPa
	07	0~200kPa	400kPa	200kPa
	08	0~350kPa	700kPa	350kPa
	09	0~700kPa	1400kPa	700kPa
	10	0~1MPa	2.0MPa	1.0MPa
	12	0~2MPa	4.0MPa	1.0MPa
	13	0~3.5MPa	7.0MPa	1.0MPa
		Code	Temperature compensation range	
		M	Outer compensated resistor (providing resistor value)	
			Code	Electric connection
			2	5-color 100mm silicon rubber flexible wires
MDM290	12	M	2	the whole spec

Order Note

1. The real measured differential pressure should be less than 80% of full scale;
2. Please identify high pressure side by marking "+", and identify low pressure side by marking "-" carefully;
3. When you use the sensor, please pay attention that the pressure added on high pressure side should be higher than pressure added on low pressure side;
4. Please pay attention to protect the diaphragm, prevent it damaging;
5. Please do not pull the 6 leading wires;
6. If the user need the sensor with larger static pressure, please contact with our company freely.