

Features

- Accuracy, $\pm 1.0\%$ FS
- Volt level output
- On-chip amplification and temperature compensations
- Pre-calibration of offset voltage and span

Applications

- Non-invasive Blood Pressure(NIBP)monitors
- Medical device

Part number for ordering

XFPM - 050KP G R - P1

Model
XFPM

Rated pressure(Pa)

Pressure type
G : Gauge

Prefix (NIBP)
P1 : Accuracy $\pm 1.0\%$ FS

Terminal leads direction (See Outline Diagram)

No mark : 

R : 

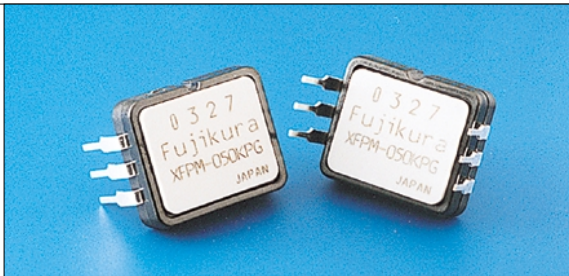
Pressure type	Gauge pressure XFPM	
Model		
Package configuration	Dual-In-line-Package (DIP)	
Measurable pressure range (kPa)	Part number for ordering	
0~50	XFPM-050KPG-P1	XFPM-050KPGR-P1

Specifications

Model/Rated pressure	050KPG(R)-P1	Unit
Recommended operating conditions		
Pressure type	Gauge pressure	—
Rated pressure	50	kPa-abs
Measurable pressure range	0~50	kPa-abs
Pressure media	Non-corrosive gas only	—
Excitation voltage	5 \pm 0.25	VDC
Absolute maximum rating		
Maximum load pressure	250	kPa-abs
Maximum excitation voltage	8	VDC
Operating temperature	-40~125	°C
Storage temperature	-40~125	°C
Operating humidity	30~80 (No dew condensation)	%RH
Electric performances/characteristics (Excitation voltage Vcc=5.0V constant, Ambient temperature Ta=25°C)		
Current consumption	less than 10	mA
Output impedance	less than 10	Ω
Source current	less than 0.2	mA
Sink current	less than 2	mA
Mechanical response time	2 (For the reference)	msec
Full scale span voltage	4.5	V
Offset voltage $\times 1$	0.2 \pm 0.045	V
Full scale span voltage $\times 1$	4.7 \pm 0.045	V
Accuracy $\times 1,2$	± 1.0	%FS/0~50°C

Note ; $\times 1$) Excluding input voltage error.

$\times 2$) Excludes offset calibration error and temperature error of offset.

■ Outline dimensions ■

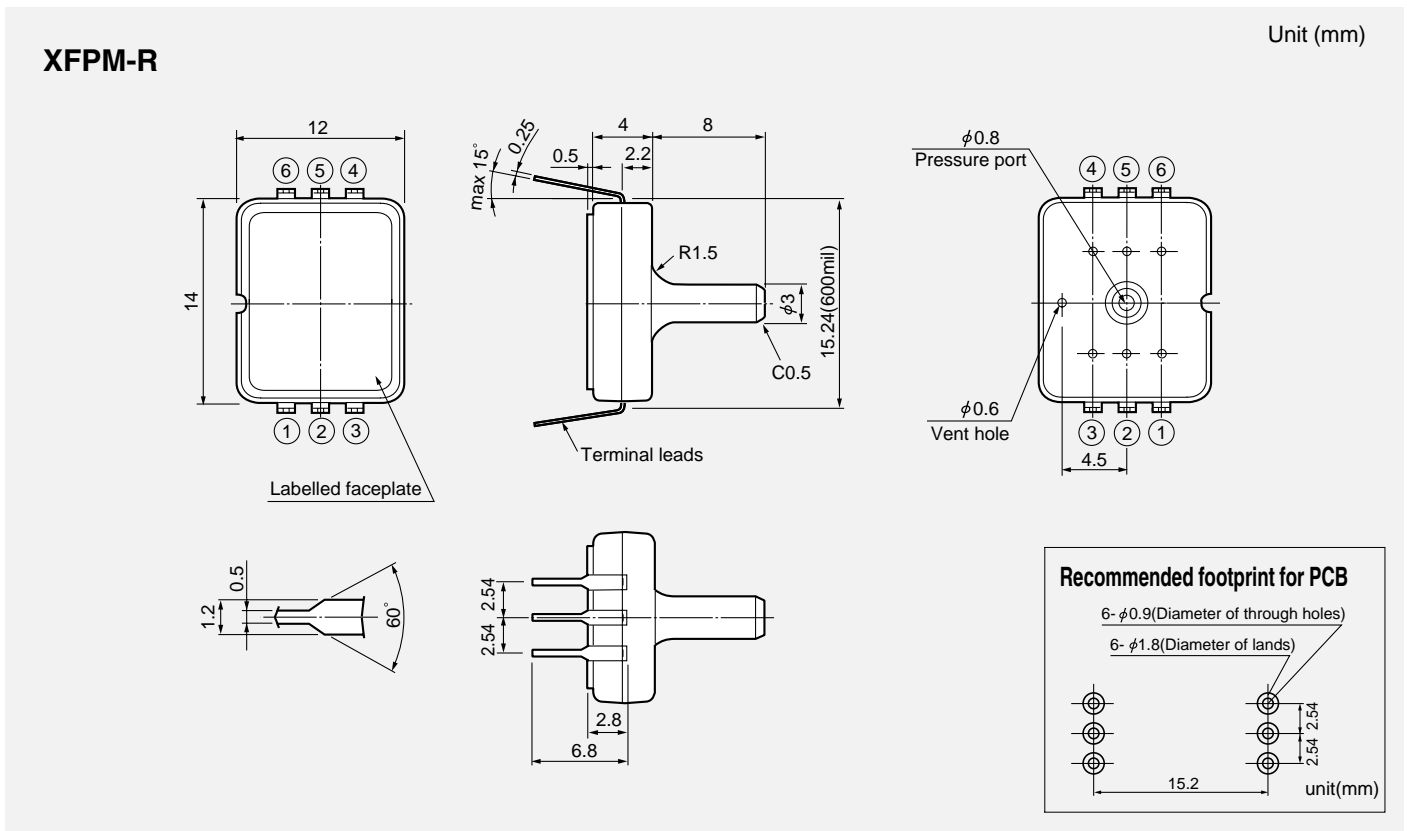
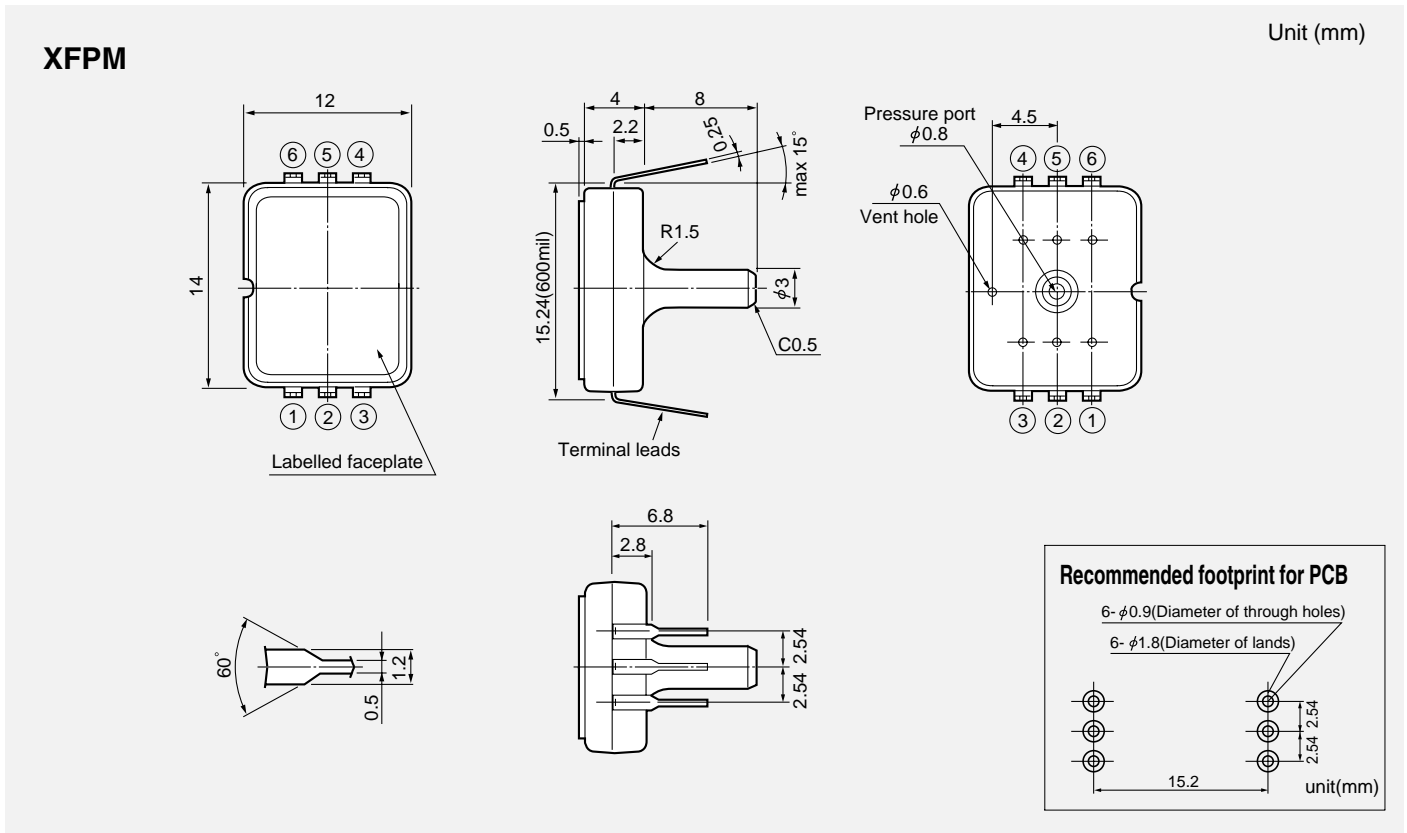

■ Connection diagram ■

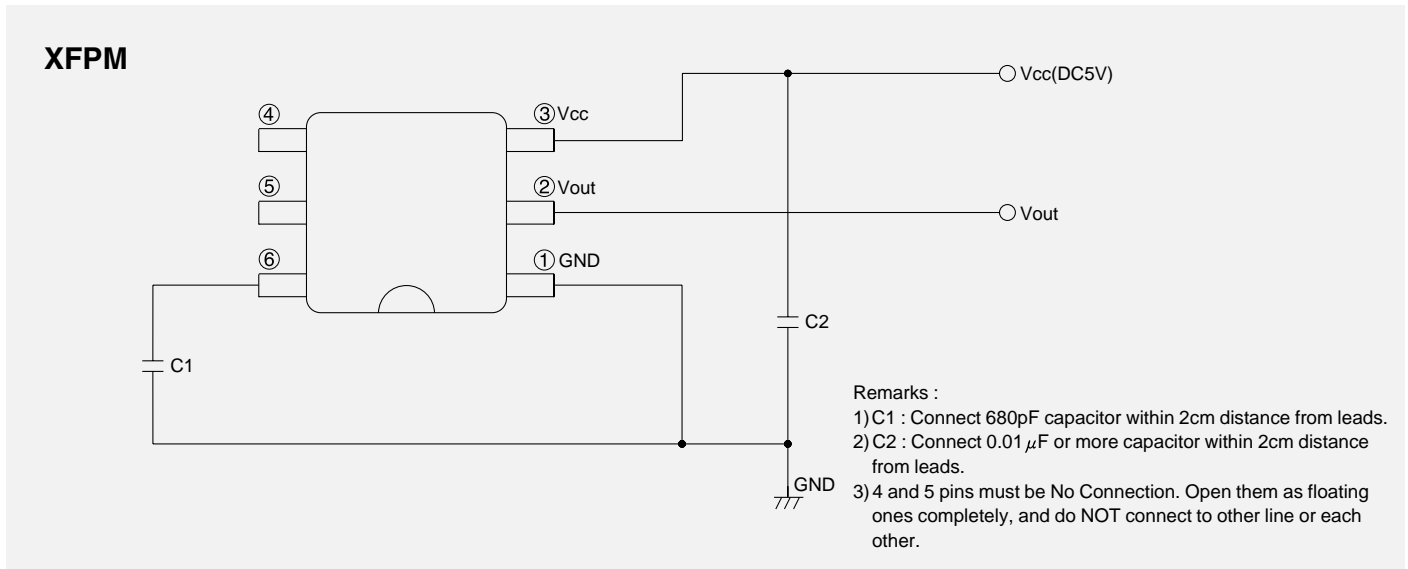

Note ; Please read instruction "Notes" before using the sensor.
Fujikura reserves the right to change specifications without notice.

Fujikura Ltd.

If you have any questions regarding technical issues or specifications, please contact our local distributor:
Servflo Corporation, 75 Allen Street, Lexington, MA 02421
Phone (781) 862-9572 Fax. (781) 862-9244
E-mail: info@servflo.com Internet: <http://www.servflo.com>