

Features

- Two accuracy ranks, $\pm 1.5\%$ FS and $\pm 2.5\%$ FS available
- Volt level output
- On-chip amplification and temperature compensations
- Pre-calibration of offset voltage and span

Applications

- Industrial instrumentation
- Medical device
- Barometer, Altimeter
- Altitude compensation

Part number for ordering

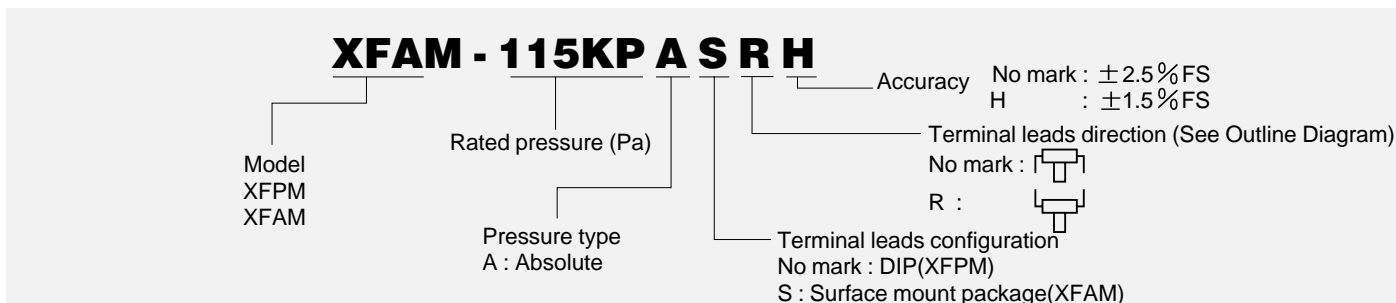

Pressure type	Absolute pressure	
	XFPM	XFAM
Model		
Package configuration	Dual-In-line-Package (DIP)	Surface mount package

Measurable pressure range (kPa)	Part number for ordering		
15 ~115	XFPM-115KPA XFPM-115KPAH	XFPM-115KPAR XFPM-115KPARH	XFAM-115KPASR XFAM-115KPASRH

Specifications

Model/Rated pressure	115KPA	115KPAH	Unit
Recommended operating conditions			
Pressure type	Absolute pressure		—
Rated pressure	115		kPa-abs
Measurable pressure range	15 ~115		kPa-abs
Pressure media	Non-corrosive gas only		—
Excitation voltage	5 \pm 0.25		VDC
Absolute maximum rating			
Maximum load pressure	Twice of rated pressure		—
Maximum excitation voltage	8		VDC
Operating temperature	-40 ~125		°C
Storage temperature	-40 ~125		°C
Operating humidity	30 ~80 (No dew condensation)		%RH
Electric performances/characteristics (Excitation voltage Vcc=5.0V constant, Ambient temperature Ta=25°C)			
Current consumption	less than 10		mA
Output impedance	less than 10		Ω
Source current	less than 0.2		mA
Sink current	less than 2		mA
Mechanical response time	2 (For the reference)		msec
Full scale span voltage	4.5		V
Offset voltage ※	0.2 \pm 0.1125	0.2 \pm 0.0675	V
Full scale span voltage ※	4.7 \pm 0.1125	4.7 \pm 0.0675	V
Accuracy ※	± 2.5	± 1.5	%FS/0~85°C

Note ; ※ Excluding input voltage error.

■ Outline dimensions ■

Unit : mm

XFPM (Absolute pressure)

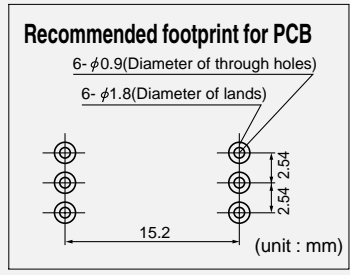
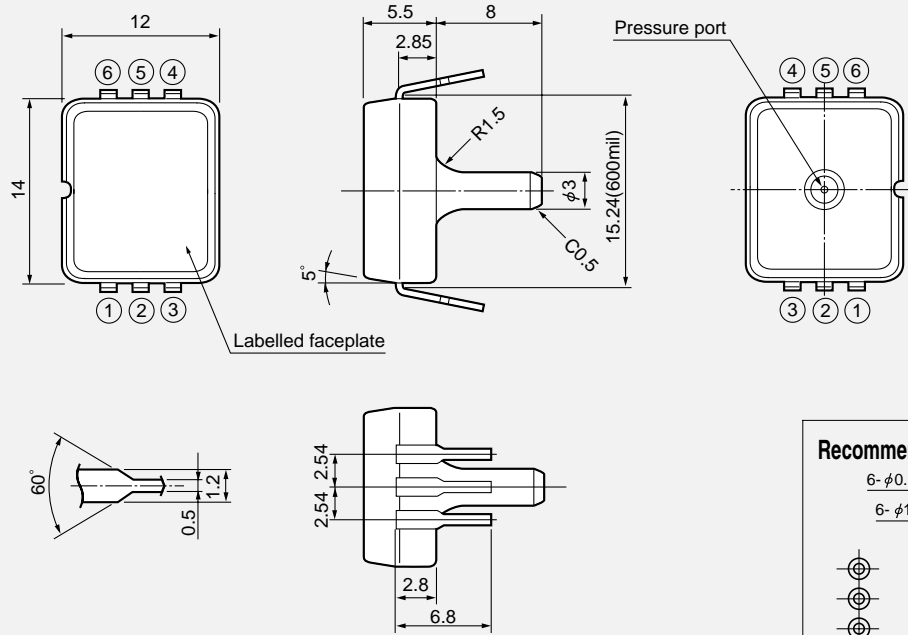

Unit : mm

XFPM-R (Absolute pressure)

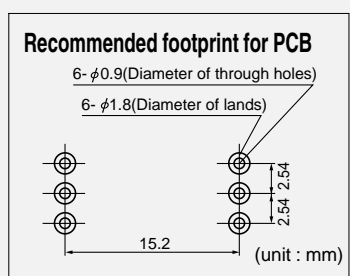
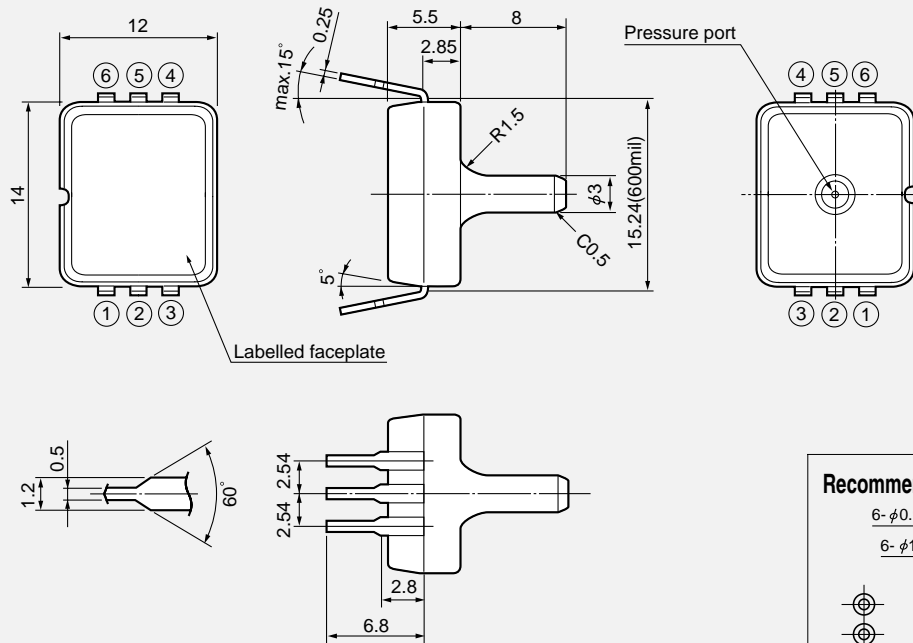

■ Outline dimensions ■

Unit : mm

XFAM

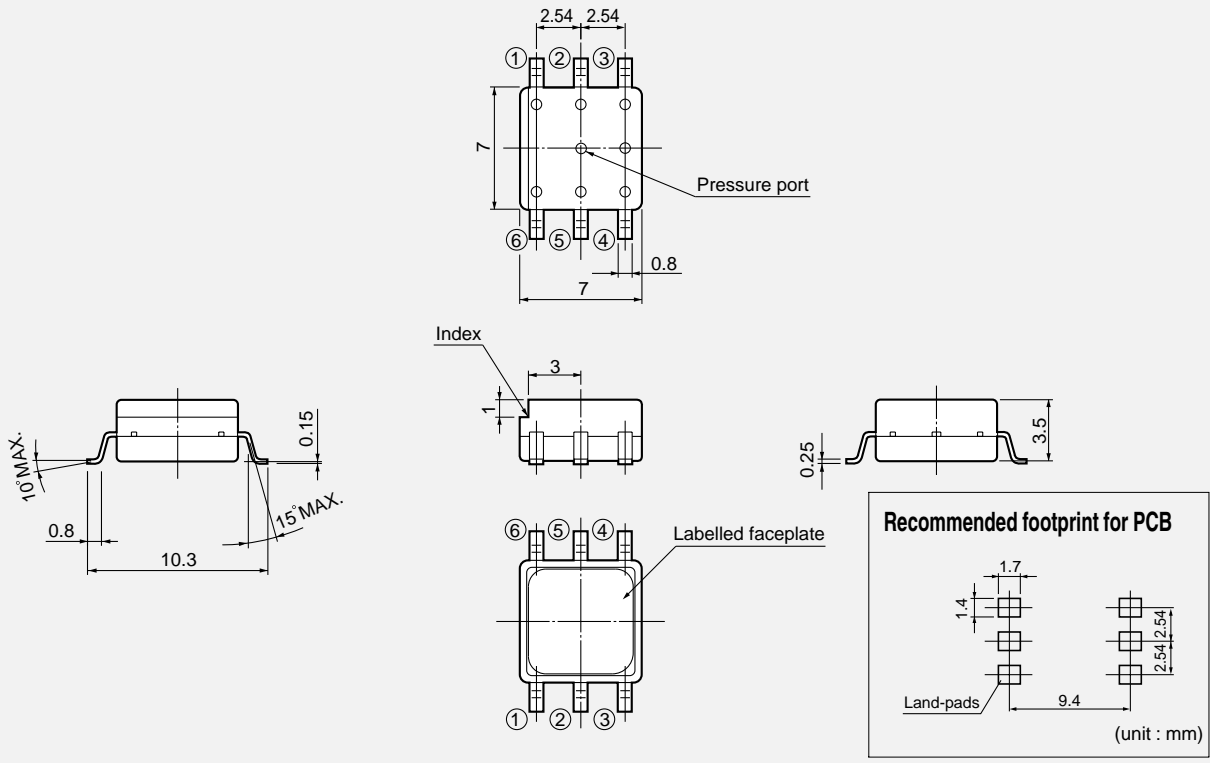

■ Connection diagram ■

XFPM (Absolute pressure)

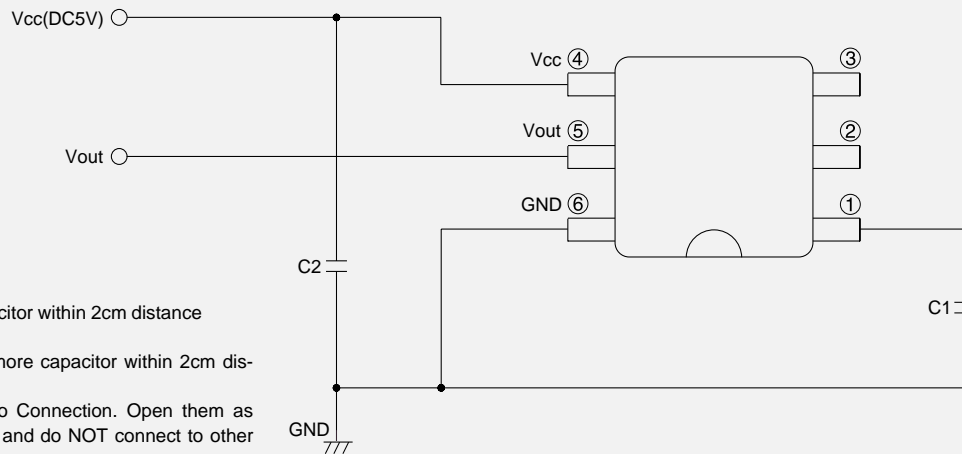

Remarks :

- 1) C1 : Connect 680pF capacitor within 2cm distance from leads.
- 2) C2 : Connect 0.01 μ F or more capacitor within 2cm distance from leads.
- 3) 2 and 3 pins must be No Connection. Open them as float-ing ones completely, and do NOT connect to other line or each other.

XFAM

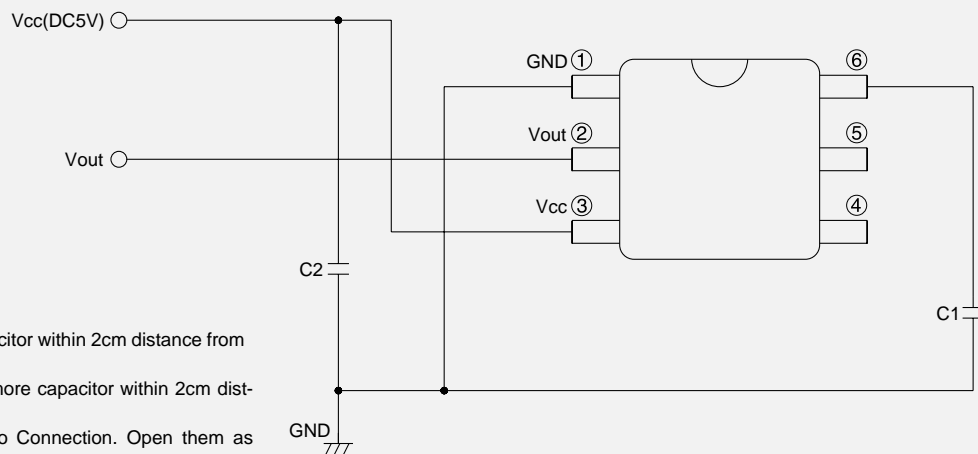

Remarks :

- 1) C1 : Connect 680pF capacitor within 2cm distance from leads.
- 2) C2 : Connect 0.01 μ F or more capacitor within 2cm distance from leads.
- 3) 4 and 5 pins must be No Connection. Open them as float-ing ones completely, and do NOT connect to other line or each other.

Note ; Please read instruction "Notes" before using the sensor.
Fujikura reserves the right to change specifications without notice.

Fujikura Ltd.

If you have any questions regarding technical issues or specifications, please contact our local distributor:
Servoflo Corporation, 75 Allen Street, Lexington, MA 02421
Phone (781) 862-9572 Fax. (781) 862-9244
E-mail: info@servoflo.com Internet: <http://www.servoflo.com>