

■ Features

- On-chip amplification and temperature compensations
- Pre-calibration of offset voltage and span
- Dual-in-line package (DIP)

■ Applications

- Home use Non-Invasive Blood Pressure (NIBP) monitors
- Vacuum cleaner
- Washing machine

■ Part number for ordering

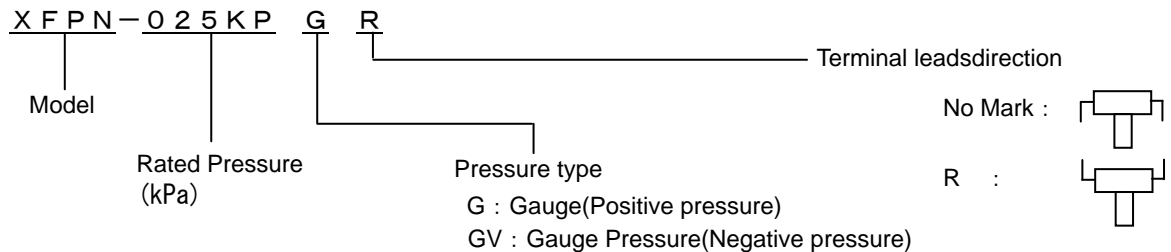

	Weight (grams)
	1.2



Measurable pressure range(kPa)	Part number for ordering	
0~-24.5	XFPN-03PGV	XFPN-03PGVR
0~-100	XFPN-100KPGV	XFPN-100KPGVR
0~25	XFPN-025KPG	XFPN-025KPGR
0~50	XFPN-050KPG	XFPN-050KPGR
0~100	XFPN-100KPG	XFPN-100KPGR
0~200	XFPN-200KPG	XFPN-200KPGR

■ Specifications

Model	03PGV	100KPGV	025KPG	050KPG	100KPG	200KPG	Unit
Recommended operating conditions							
Pressure type	Gauge pressure						—
Rated pressure	-24.5	-100	25	50	100	200	kPa
Measurable pressure range	0~-24.5	0~-100	0~25	0~50	0~100	0~200	kPa
Temperature range	0~50						°C
Pressure media	Non-corrosive gases only (No liquid)						—
Supply voltage (constant)	5±0.25						VDC
Absolute maximum rating							
Maximum load pressure	Twice of rated pressure						—
Maximum excitation voltage	8						VDC
Operating temperature	-10~80						°C
Storage temperature	-20~100						°C
Operating humidity	30~80 (Non dew condition)						%RH
Electrical characteristics (Excitation voltage Vcc=5.0V constant ,ambient temperature Ta=25°C)							
Power consumption	10mA max.						mA
Output impedance	10Ω max.						Ω
Source current	0.2mA max.						mA
Sink current	2mA max.						mA
Response time	2 (for the reference)						msec
Output span voltage	4.0						V
Offset voltage *	0.5±0.1 (at 0 kPa)						V
Output voltage at full scale *	4.5±0.1 (at rated pressure)						V
Accuracy *	±5.0						%FS/0~50°C

* Excluding input voltage error.

■ Outline dimensions ■

Unit : mm

XFPN

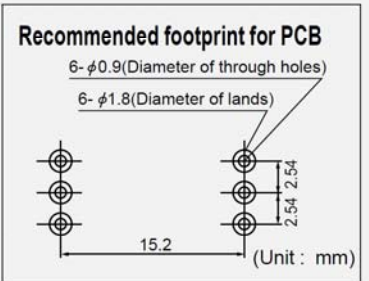
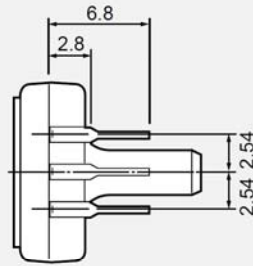
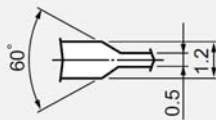
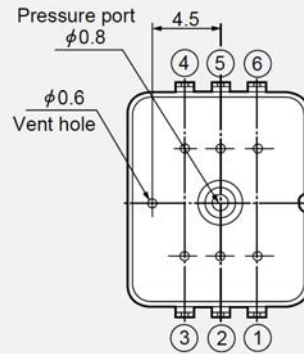
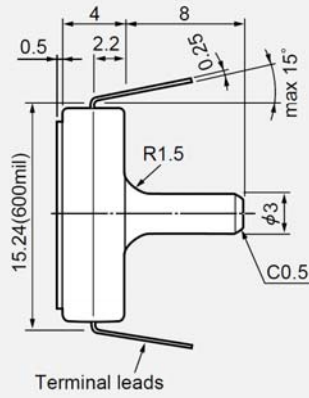
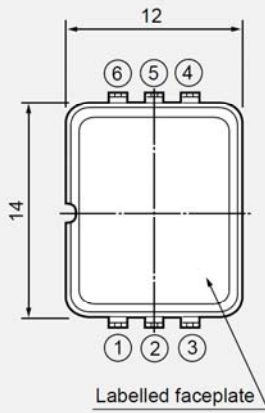

XFPN-R

Unit : mm

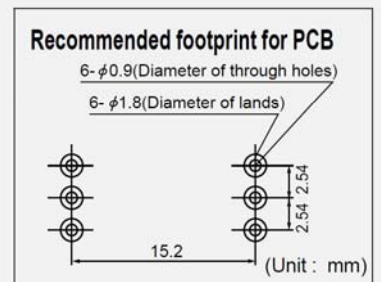
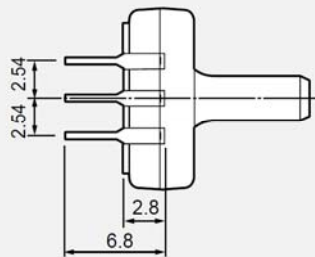
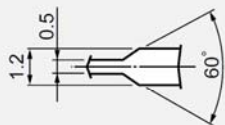
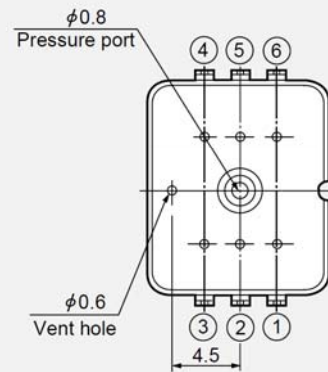
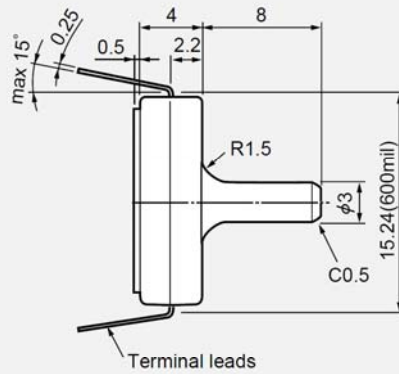
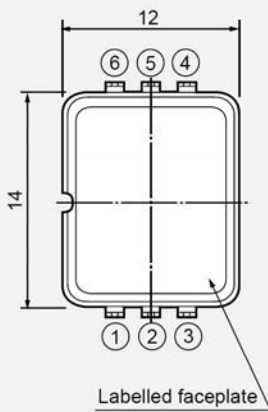

■ Connection diagram ■

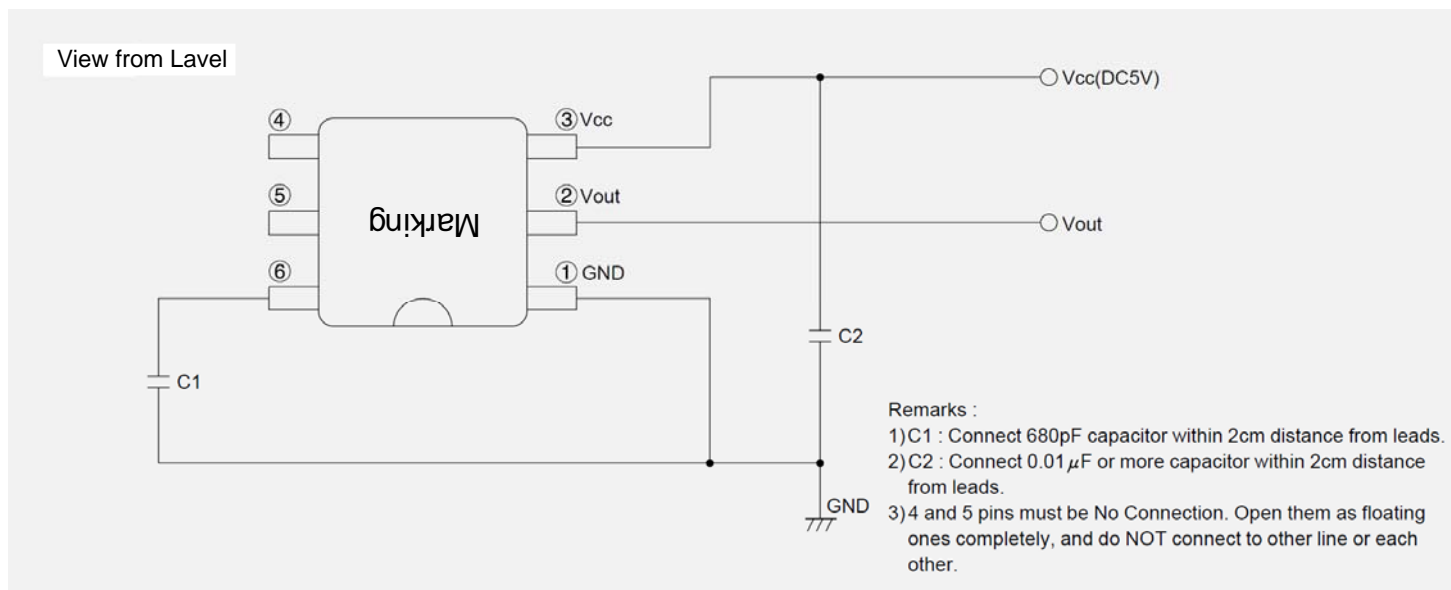

■ Transfer Function ■

$$V_{out} = V_s \times (P \times \alpha + \beta) \pm (\text{Pressure Error} \times \text{Temperature Error Multiplier} \times \alpha \times V_s)$$

$$V_s = V_{cc} = 5.0V$$

$$P = \text{Input pressure (kPa)}$$

Model		Measurable pressure range(kPa)	α	β	Pressure Error (kPa)
XFPN-03PGV	XFPN-03PGVR	0 ~ -24.5	-0.03266	0.1	0.612
XFPN-100KPGV	XFPN-100KPGVR	0 ~ -100	-0.008	0.1	2.5
XFPN-025KPG	XFPN-025KPGR	0 ~ 25	0.032	0.1	0.625
XFPN-050KPG	XFPN-050KPGR	0 ~ 50	0.016	0.1	1.25
XFPN-100KPG	XFPN-100KPGR	0 ~ 100	0.008	0.1	2.5
XFPN-200KPG	XFPN-200KPGR	0 ~ 200	0.004	0.1	5

Temperature Error Multiplier

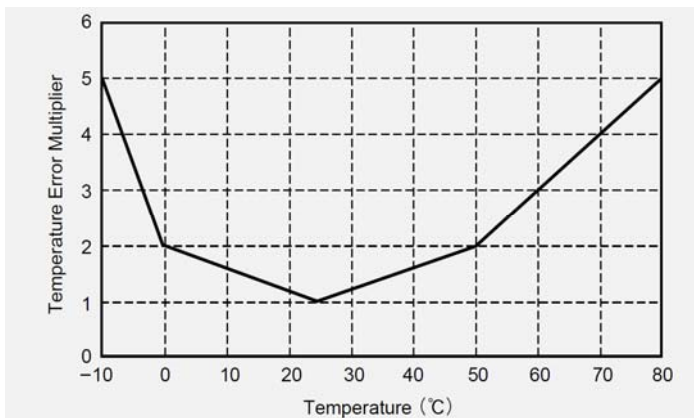

■ Output characteristics ■

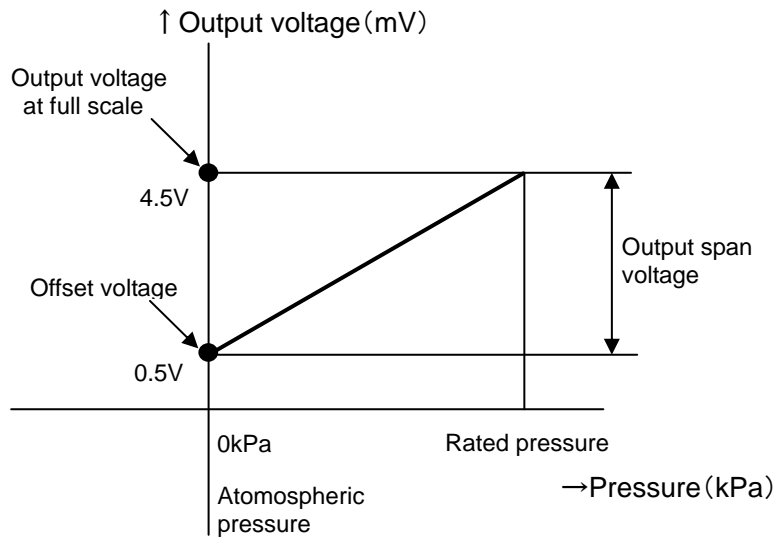

Note ; Please read instruction “Notes” before using the sensor.
Fujikura reserves the right to change specifications without notice.

If you have any questions regarding technical issues or specifications, please contact us.
Sensor Engineering Department 5-1 Kiba 1-chome, Koto-ku, Tokyo 135-8512, Japan
Phone +81-(0)3-5606-1072
E-mail : sensor@fujikura.co.jp